

# Nord Technology

*Reseller of Compulab hardware in Denmark*

## NORD TECHNOLOGY CONTACT INFORMATION

World Trade Center  
Borupvang 3,  
2750 Ballerup,  
Denmark

-  **Tel.:** +45 70 27 04 15
-  **Email:** sales@nord-t.eu
-  **Website:** www.nordtechnology.dk

## *IOT-DIN-IMX8PLUS IoT Edge Gateway*



# IOT-DIN-IMX8PLUS

User's Manual



© 2024 Compulab Ltd.

All Rights Reserved. No part of this document may be photocopied, reproduced, stored in a retrieval system, or transmitted, in any form or by any means whether, electronic, mechanical, or otherwise without the prior written permission of Compulab Ltd.

No warranty of accuracy is given concerning the contents of the information contained in this publication. To the extent permitted by law, no liability (including liability to any person by reason of negligence) will be accepted by Compulab Ltd., its subsidiaries or employees for any direct or indirect loss or damage caused by omissions from or inaccuracies in this document.

Compulab Ltd. reserves the right to change details in this publication without notice.

Product and company names herein may be the trademarks of their respective owners.

Compulab Ltd.  
P.O. Box 687 Yokneam Illit  
20692 ISRAEL  
Tel: +972 (4) 8290100  
<https://www.compulab.com>  
Fax: +972 (4) 8325251

## Table of Contents

<b>1</b>	<b>INTRODUCTION .....</b>	<b>5</b>
1.1	About This Document .....	5
1.2	IOT-DIN-IMX8PLUS Part Number .....	5
1.3	Related Documents .....	5
<b>2</b>	<b>OVERVIEW.....</b>	<b>6</b>
2.1	Highlights .....	6
2.2	Safety Instructions .....	6
2.3	Specifications .....	7
2.4	Ordering Information.....	8
2.5	I/O Expansion Modules Stacking Rules.....	8
<b>3</b>	<b>INTERFACE LAYOUT AND CONNECTORS.....</b>	<b>9</b>
3.1	Front Panel.....	9
3.2	Bottom Panel .....	10
3.3	Right Panel .....	11
3.4	Power Input Connector .....	12
3.5	System Status LED.....	12
3.6	Industrial I/O Connector .....	13
<b>4</b>	<b>PACKAGE CONTENT .....</b>	<b>14</b>
4.1	Gateway Package Content .....	14
4.2	I/O Expansion Modules Package Content .....	15
<b>5</b>	<b>PREPARING THE GATEWAY FOR OPERATION .....</b>	<b>16</b>
5.1	SIM Card Installation.....	16
5.1.1	SIM Card Installation .....	16
5.2	Installing I/O Expansion Modules .....	17
5.2.1	I/O Expansion Modules Stacking Rules .....	17
5.2.2	Attaching I/O Expansion Modules .....	18
5.2.3	Detaching I/O Expansion Modules .....	18
5.3	Mounting the Gateway.....	19
5.3.1	Attaching Gateway to DIN Rail .....	20
5.3.2	Detaching Gateway from DIN Rail .....	20
<b>6</b>	<b>OPERATING THE GATEWAY.....</b>	<b>21</b>
6.1	Connecting with the gateway .....	21
6.2	Powering on the gateway .....	21
6.3	Gateway Software .....	21
<b>7</b>	<b>DECLARATION OF CONFORMITY .....</b>	<b>22</b>

**Table 1 Revision Notes**

Date	Description
May 2024	<ul style="list-style-type: none"> <li>• Initial release</li> </ul>

Please check for a newer revision of this manual at the CompuLab website <https://www.compulab.com>. Compare the revision notes of the updated manual from the website with those of the printed or electronic version you have.

# 1 INTRODUCTION

---

## 1.1 About This Document

This document is a guide providing information necessary to operate and maintain CompuLab IOT-DIN-IMX8PLUS Gateway.

## 1.2 IOT-DIN-IMX8PLUS Part Number

To decode the IOT-DIN-IMX8PLUS part number please refer to the 'Ordering' section of the IOT-DIN-IMX8PLUS product page: <https://www.compulab.com/products/iot-gateways/iot-din-imx8plus-industrial-iot-gateway/#ordering>.

## 1.3 Related Documents

For additional information, refer to the documents listed in Table 2.

**Table 2 Related Documents**

Document	Location
IOT-DIN-IMX8PLUS Resources	<a href="https://www.compulab.com/products/iot-gateways/iot-din-imx8plus-industrial-iot-gateway/">https://www.compulab.com/products/iot-gateways/iot-din-imx8plus-industrial-iot-gateway/</a>

## 2 OVERVIEW

### 2.1 Highlights

IOT-DIN-IMX8PLUS is an industrial IoT gateway with integrated DIN rail latch mechanism and modular I/O Expansion modules.

- CPU: NXP i.MX8M Plus, quad-core Cortex-A53, 1.8GHz
- DRAM : Up to 8GB RAM ; Storage: Up to 128GB eMMC
- Built-in interfaces: 2x LAN, USB3.0, TPM2.0, RS485, RS232, CAN bus, 2x DI + 2x DO
- Optional LTE/4G global modem
- Stackable I/O Expansion modules:
  - Serial – up to 12x RS485 | RS232
  - Digital I/O – up-to 32x DO + 32x DI
  - ADC – up to 8 channels
  - Wireless: 802.11ax WiFi and Bluetooth 5.3 BLE
- Several temperature rating options:
  - Commercial: 0°C to 50°C
  - Industrial: -30°C to 70°C
- Operating systems: Debian Linux; Yocto Project; Balena OS

### 2.2 Safety Instructions

Use the following safety guidelines to help protect your IOT-DIN-IMX8PLUS from potential damage and to ensure your personal safety. Unless otherwise noted, all procedures outlined in this document assumes that you have read the safety instructions.

 **WARNING:** Never assemble or disassemble I/O Expansion modules while under power. Disconnect all power sources before opening the covers of the gateway or I/O Expansion modules.

 **CAUTION:** Some repairs may only be done by a certified service technician. You should only perform troubleshooting and simple repairs as authorized in your product documentation, or as directed by the online or telephone service and support team. Damage due to servicing that is not authorized by Compulab is not covered by your warranty. Read and follow the safety instructions that came with the product.

 **CAUTION:** When disconnecting a cable, always pull on its connector or pull-tab, not on the cable itself. Certain cables may feature connectors with locking tabs; for such cables, remember to unscrew the locking tabs before disconnecting. As you separate connectors, maintain even alignment to prevent bending of any connector pins. Additionally, before connecting a cable, ensure that both connectors are correctly oriented and aligned.

 **CAUTION:** Avoid applying excessive physical force during mechanical assembly or DIN-Rail mounting. The gateway and extension modules are designed for easy assembly, ensuring smooth mating of the parts. If excessive force is required, it indicates a misalignment. Please exercise care and precision to prevent damage.

## 2.3 Specifications

The "Option" column specifies the IOT-DIN-IMX8PLUS configuration option required to have the feature.

"+" means that the feature is always available.

**Table 3 Features and Configuration options.**

Feature	Description	Option
<b>CPU Core and Graphics</b>		
CPU	NXP i.MX8M Plus QuadLite, quad-core ARM Cortex-A53, 1.8GHz	C1800Q
	NXP i.MX8M Plus Quad, quad-core ARM Cortex-A53, 1.8GHz	C1800QM
NPU	AI/ML Neural Processing Unit, up to 2.3 TOPS	C1800QM
Real-Time Co-processor	ARM Cortex-M7, 800Mhz	+
<b>Memory and Storage</b>		
RAM	1GB – 8GB, LPDDR4	D
Storage	eMMC flash, soldered on board 16GB - 64GB	N
<b>Network</b>		
LAN	2x GBit Ethernet, RJ45 connectors	+
Cellular	4G/LTE CAT4 cellular module, Quectel EG25G Worldwide LTE, UMTS/HSPA+ and GSM/GPRS/EDGE coverage	JEG25G
	SIM card Socket	+
<b>I/O</b>		
USB	1x USB3.0 port, type-A connector	+
Serial	1x RS485, two-wire port Isolated, terminal-block connector	+
	1x RS232, Rx/Tx Isolated, terminal-block connector	
CAN bus	1x CAN bus port Isolated, terminal-block connector	+
Digital I/O	2x digital outputs + 2x digital inputs Isolated, 24V compliant with EN 61131-2, terminal-block connector	+
Debug	Serial console via UART-to-USB bridge, micro-USB connector	+
	NXP SDP programming port, micro-USB connector	+
<b>I/O Expansion modules</b>		
Wireless	802.11ax WiFi and Bluetooth 5.3 BLE Implemented with Intel WiFi 6E AX210 module 2x RP-SMA connectors Stacking restrictions: one wireless module	FAWB
RS485	4x RS485, two-wire Isolated, terminal-block connector Stacking restrictions: up-to 3 RS485   RS232 modules	FxRS4
RS232	4x RS232, Rx/Tx Isolated, terminal-block connector Stacking restrictions: up-to 3 RS485   RS232 modules	FxRS2
Digital I/O	8x digital outputs + 8x digital inputs Isolated, 24V compliant with EN 61131-2, terminal-block connector Stacking restrictions: up-to 4 digital I/O modules	FxDI808
ADC	8x analog inputs, 0...10V / 4...20mA Isolated, terminal block connector Stacking restrictions: one ADC module	FxADC
<b>System</b>		
RTC	Real time clock operated from on-board coin-cell battery	+



Feature	Description	Option
Watchdog	Hardware Watchdog	+
Security	Secure boot, implemented with i.MX8M Plus HAB module	+
	TPM 2.0, Infineon SLB9673	
Indicators	2x programmable dual-color LEDs	+

**Table 4 Electrical, Mechanical and Environmental Specifications**

Electrical Specifications	
Power Supply	12V-24V DC (-20%/+20%) Reverse voltage protection
Power consumption	2.5 - 8 W, depending on system load and device configuration
Mechanical Specifications	
Housing type	DIN rail housing (for DIN rail version EN 50022)
Housing material	ABS/PC high endurance
Dimensions	Gateway – 110 x 30 x 95 mm I/O Expansion module – 110 x 20 x 95 mm
Cooling	Passive cooling, fanless design
Weight	Gateway – 0.22 kg I/O Expansion module – 0.11 kg
Terminal blocks connectors	0.2-1.5mm <sup>2</sup> ; 16-26 AWG;
Environmental and Reliability	
MTTF	> 200,000 hours
Operation temperature	Commercial: 0° to 50° C
	Industrial: -40° to 70° C
Storage temperature	-40° to 85° C
Relative humidity	10% to 90% (operation)
	05% to 95% (storage)

## 2.4 Ordering Information

For up-to-date information about available configurations, ordering guidelines and accessories please refer to the 'Ordering' section of the IOT-DIN-IMX8PLUS product page:

<https://www.compulab.com/products/iot-gateways/iot-din-imx8plus-industrial-iot-gateway/#ordering>

## 2.5 I/O Expansion Modules Stacking Rules

To learn about allowed combinations and stacking rules of I/O Expansion modules please refer to section 5.2.1.

### 3 INTERFACE LAYOUT AND CONNECTORS

#### 3.1 Front Panel

Figure 1 Front Panel Layout

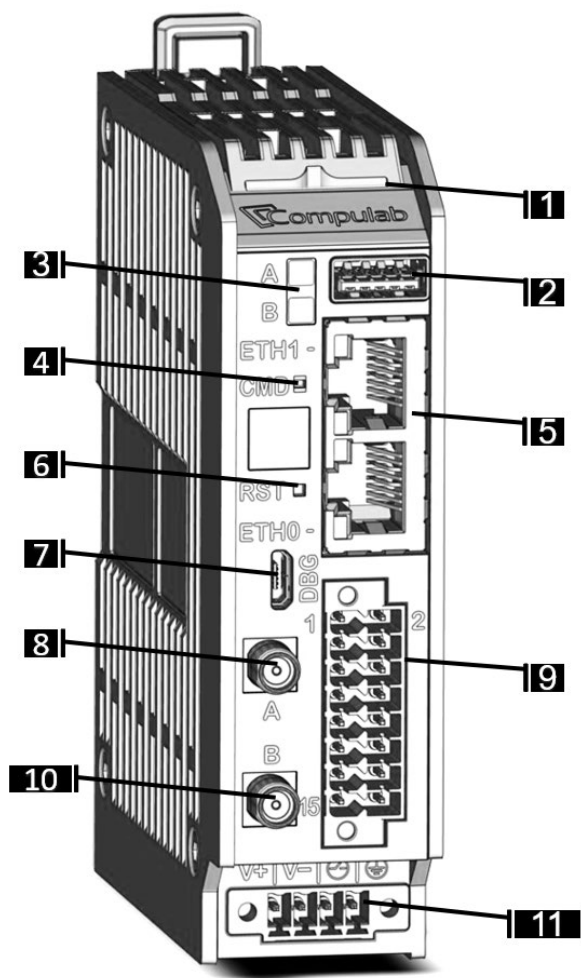

Table 5 Front Panel Layout

Callout	Description
1	System status indicator. Dual-color blue/amber LED
2	USB 3.0 connector
3	User programmable LED A & LED B
4	User programmable recessed push-button
5	Ethernet ports, dual RJ45 connector
6	System reset push-button
7	Console connector, micro-USB type
8	Antenna A, SMA RP *
9	Industrial I/O terminal block, 16 pin, 16-26 AWG
10	Antenna B, SMA *
11	Power input connector

\*: Present only in configurations with cellular modem

### 3.2 Bottom Panel

Figure 2 Bottom Panel Layout

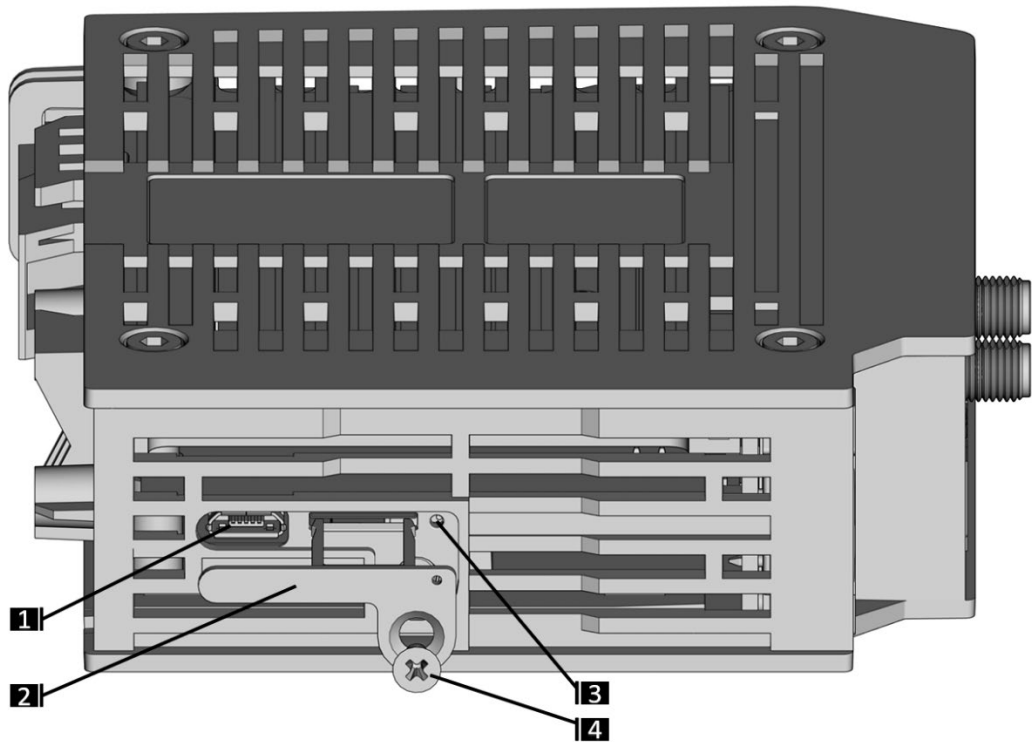

Table 6 Bottom Panel Layout

Callout	Description
1	SDP programming port, micro-USB type
2	SIM card tray
3	Tray retraction lever
4	Locking screw (Philips head)

### 3.3 Right Panel

Figure 3 Right Panel Layout

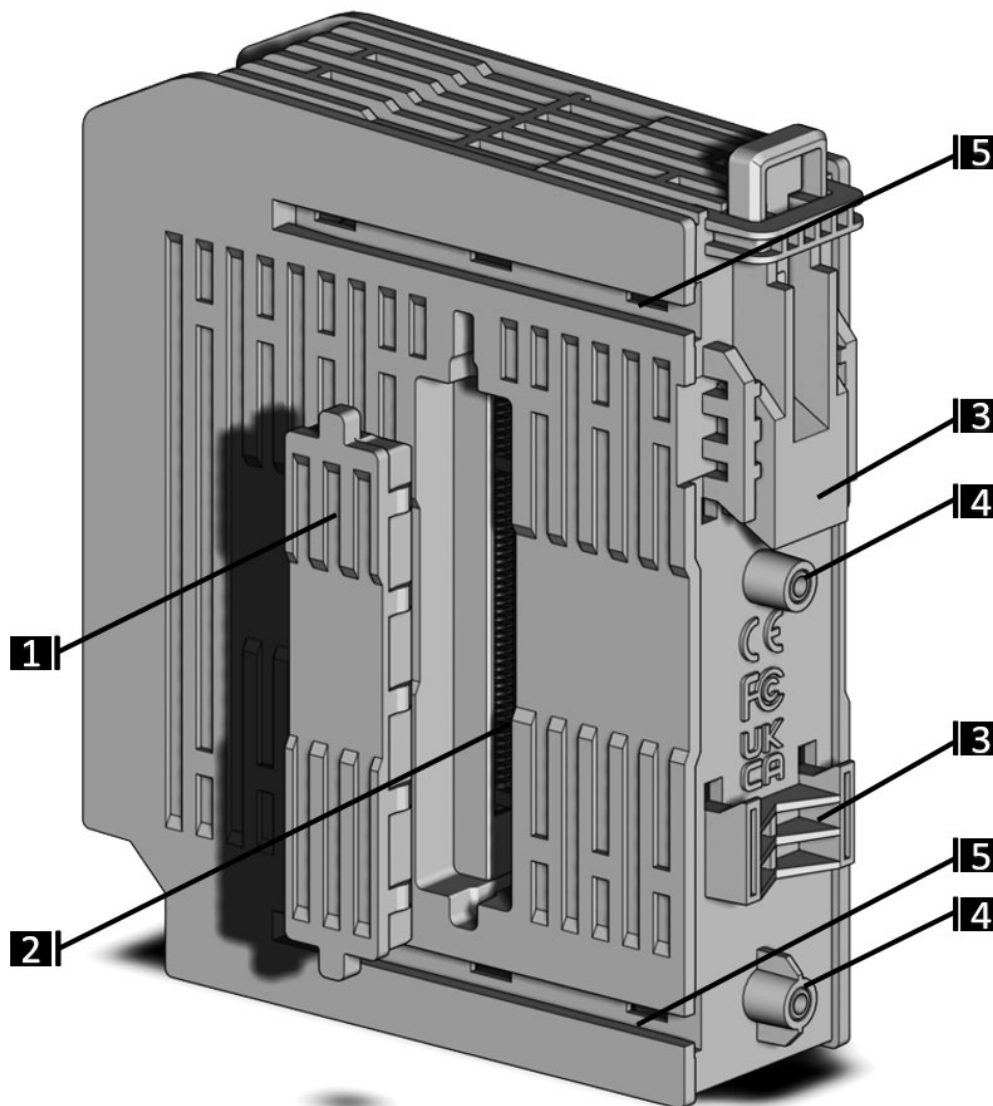

Table 7 Right Panel Layout

Callout	Description
1	Silicone protective cover
2	StackLink expansion connector
3	DIN-rail mounting mechanism with built-in latch
4	M3 threads for non-DIN mounting
5	Rails for secure clamps

### 3.4 Power Input Connector

Figure 4 Power Input Connector

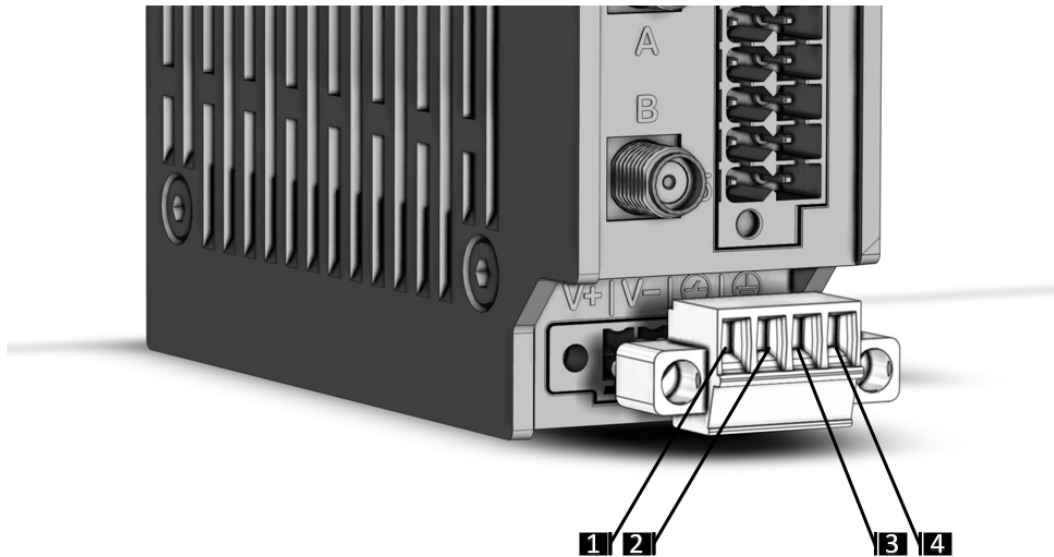

Table 8 Power Connector Pinout

Callout	Description
1	V+ DC pin (for wire 16-20 AWG)
2	V0 DC pin (for wire 16-20 AWG)
3	Programmable power control
4	Protective Earth connection

**Warning: Connecting the Remote Power Button input to DC voltage may damage the device.  
 \*\*\* Only connect the input pin to GND via contact switch \*\*\***

### 3.5 System Status LED

The System Status LED provides basic indication regarding Gateway status.

Table 9 System Status LED

LED State	Gateway Status
OFF	System is in OFF or deep-sleep state
Solid BLUE	System is running U-boot bootloader
Solid PURPLE	U-boot bootloader is not running. Indicates bootloader corruption
Blinking BLUE	System is running Linux O/S. Normal operation mode
Blinking AMBER	Invalid combination of I/O expansion modules detected

### 3.6 Industrial I/O Connector

Industrial I/O connector is a 16-pin dual-row terminal block with a separate push-in spring contact mating plug. The spring contacts can be used with 16-26 AWG wires.

The mating plug is supplied with the gateway unit.

For more technical information please refer to the IOT-DIN-IMX8PLUS reference guide.

**Table 10 Industrial I/O connector pin-out**

Pin	Function	Signal Name
1	DIO	DIO_VIN
2	DIO	DIO_IN0
3	DIO	DIO_OUT0
4	DIO	DIO_IN1
5	DIO	DIO_OUT1
6	DIO	DIO_COM
7	RS485	RS485_D-
8	RS485	RS485_D+
9	RS485	RS485_TRM
10	RS485	RS485_COM
11	RS232	RS232_RxD
12	RS232	RS232_TxD
13	CAN	CAN_COM
14	RS232	RS232_COM
15	CAN	CAN_L
16	CAN	CAN_H

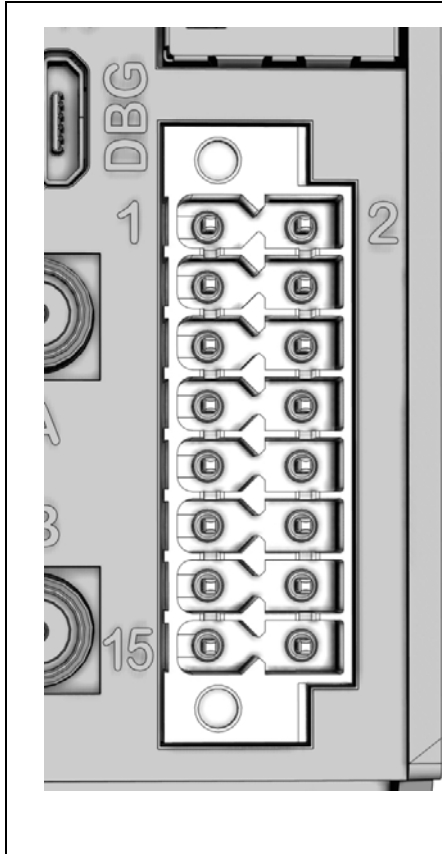

## 4 PACKAGE CONTENT

### 4.1 Gateway Package Content

Figure 5 Gateway package content

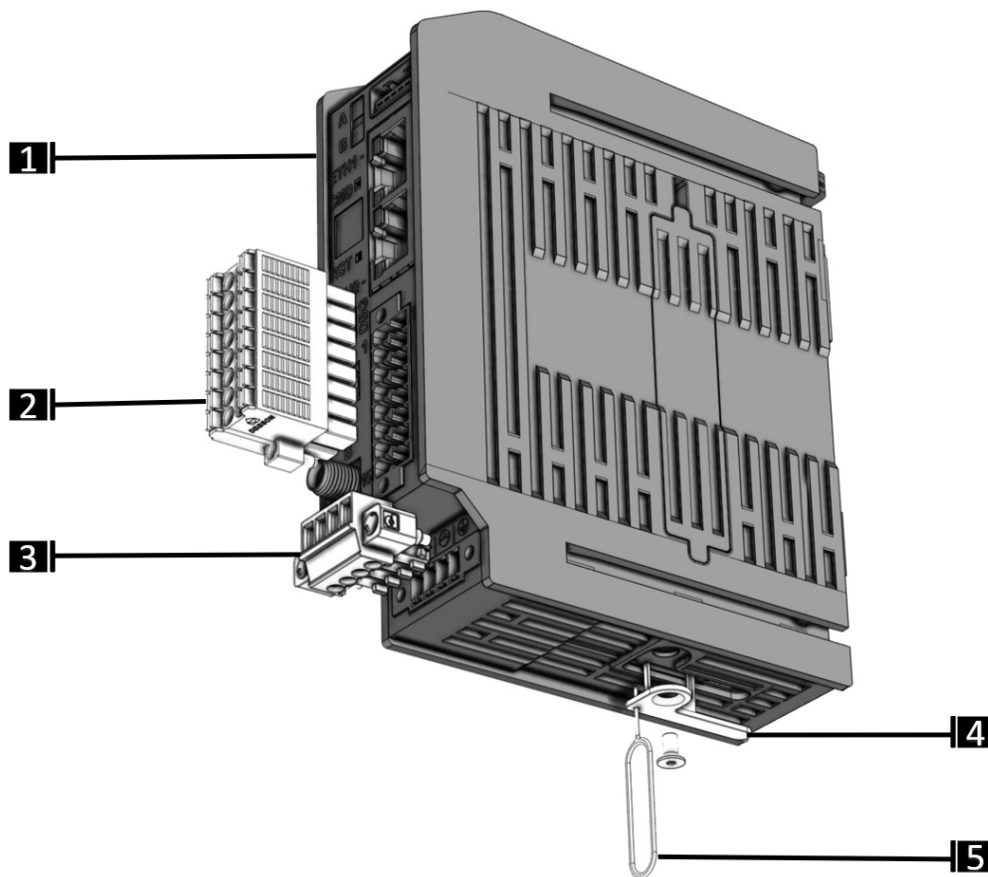

Table 11 Gateway package content

Callout	Description	Quantity
1	IOT-DIN-IMX8PLUS gateway	1
2	16-pin terminal block mating plug (black)	1
3	4-pin power connector mating plug (green)	1
4	SIM card tray + screw	1
5	SIM card ejector pin	1

## 4.2 I/O Expansion Modules Package Content

Different I/O Expansion Modules have different package content. Please see the reference table below.

**Figure 6 I/O Expansion Module package content illustration**

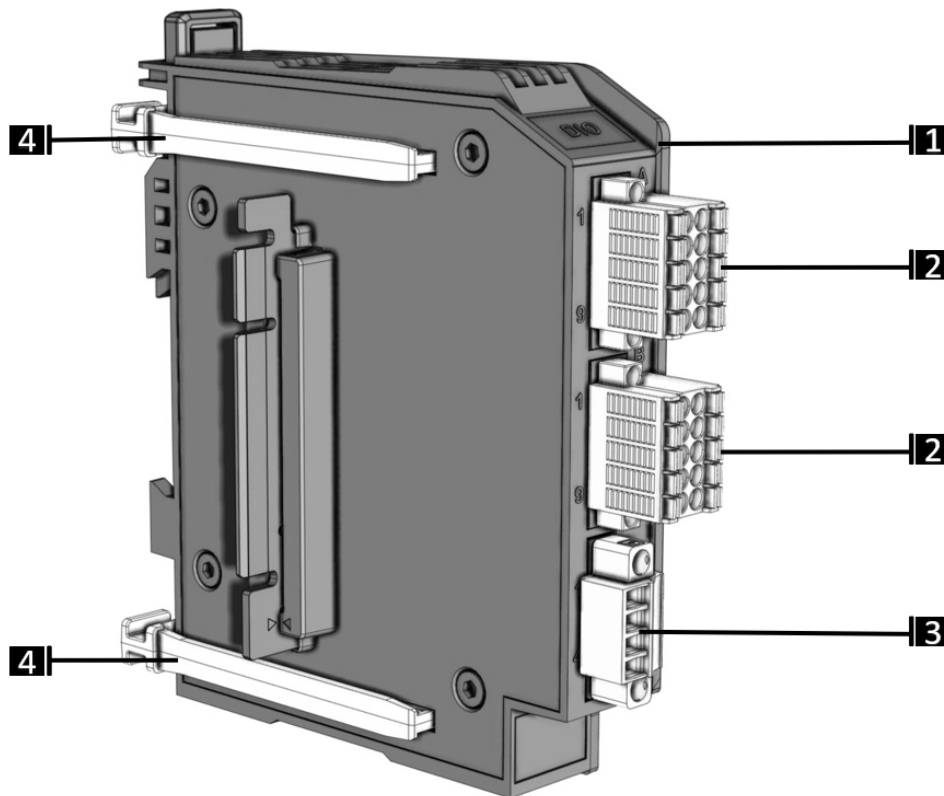

**Table 12 I/O Expansion Module package content description**

Callout	Item & Description
1	I/O Expansion Module
2	10-pin mating plug (black)
3	4-pin mating plug (green)
4	Secure clamps

**Table 13 I/O Expansion Module package content reference table**

	IFM-WB	IFM-RS485	IFM-RS232	IFM-DI808	IFM-ADC
4-pin mating plug (green)	-	-	-	1	-
10-pin mating plug (black)	-	2	2	2	2
Secure clamp	2	2	2	2	2
WiFi antenna	2	-	-	-	-



## 5 PREPARING THE GATEWAY FOR OPERATION

### 5.1 SIM Card Installation

**NOTE:** the tray is present in all gateway configurations. For SIM card installation, verify the gateway configuration includes the cellular modem.

**NOTE:** IOT-DIN-IMX8PLUS utilizes the nano-SIM card format.

**NOTE:** The SIM card tray screw can be replaced with a secure TORX screw. Kindly refer to customer support for guidance.

#### 5.1.1 SIM Card Installation

- Disconnect the gateway from the power
- The SIM card slot is located on the bottom side of the gateway
- If the SIM tray is installed, remove the screw, and push with the ejector pin on the lever
- Place the SIM card in the tray
- Carefully insert the tray into the designated slot
- Secure the tray into the gateway with the provided screw using a Philips screwdriver. Ensure proper alignment with the housing
- To remove the tray, disconnect the power, remove the screw, and push with the ejector pin on the lever

**Figure 7** SIM card installation

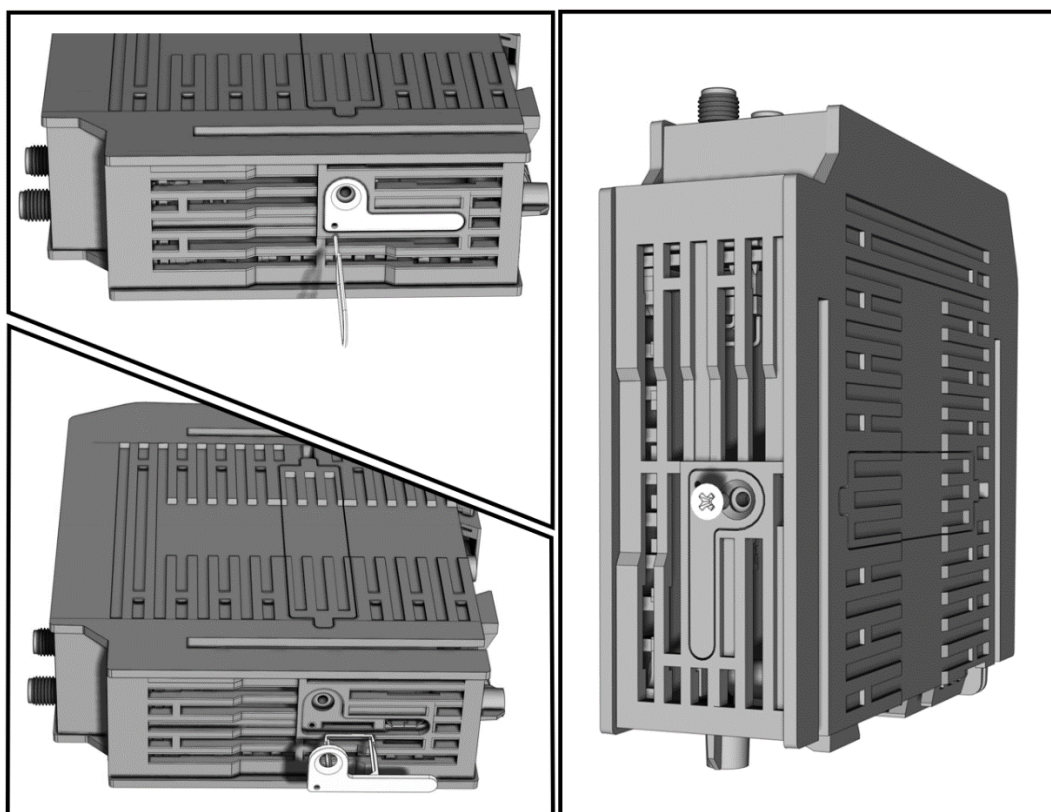

## 5.2 Installing I/O Expansion Modules

Each assembly includes one gateway (the left most unit) and multiple I/O Expansion modules. Module stacking is done from left to right.

It is not possible to stack two gateways together.

I/O expansion modules cannot operate stand-alone without a connection to the gateway.



**WARNING:** DO NOT attach or detach I/O Expansion modules while the gateway is connected to DC power. All power sources must be disconnected from the gateway before attaching or detaching I/O modules.



**NOTE:** Verify that the StackLink I/O bridge is present on the I/O Expansion Module and correctly oriented.

### 5.2.1 I/O Expansion Modules Stacking Rules

- There can be up-to 8 I/O Expansion Modules in one assembly
- IFM-WB modules can only be installed in position A (next to main gateway)
- There can be up-to 3 (in total) modules of types IFM-RS485, IFM-RS232, IFM-WB
- There can be up-to 4 IFM-DI8O8 modules
- There can be only 1 IFM-ADC8 module

## 5.2.2 Attaching I/O Expansion Modules

- Remove the silicone plug covering the StackLink receptacle opening on the left side of the gateway
- Align the gateway and the module so that the StackLink I/O bridge is against the receptacle
- Gently push the devices together until you hear a soft click and no gap is left between the units
- Install the secure clamps into the top and bottom clamp rails on the rear side of the assembly. Verify that the devices are secured together.

## 5.2.3 Detaching I/O Expansion Modules

- Remove the secure clamps from the top and bottom clamp rails on the rear side of the assembly. A thin screwdriver tip can be inserted into the clamp's handle and used as a lever.
- Gently pull the modules apart. The StackLink I/O bridge should remain attached to the right-side module.
- Cover the StackLink receptacle opening on the gateway with the silicone plug.

**Figure 8 Attaching I/O Expansion Modules**

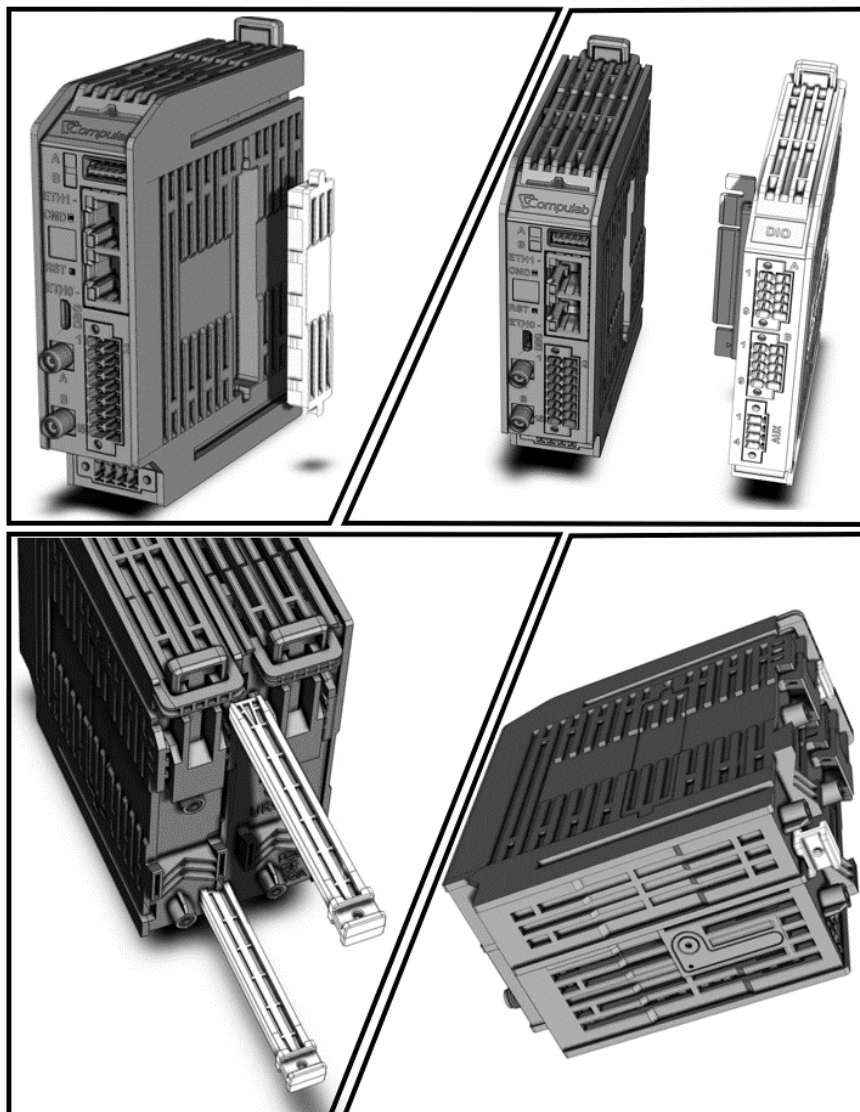

## 5.3 Mounting the Gateway

**⚠ CAUTION:** Never leave the Gateway unsecured on the DIN rail with open latches.

Do not pull the gateway assembly by the cables on the DIN rail.

**⚠ NOTE:** Do not obstruct the top and bottom airways of the gateway. Leave a 50 mm air gap from the top and bottom of the gateway to facilitate effective heat dissipation

**⚠ NOTE:** Do not place foreign objects on top of the gateway assembly

**Figure 9 IOT-DIN-IMX8PLUS DIN rail mounting**

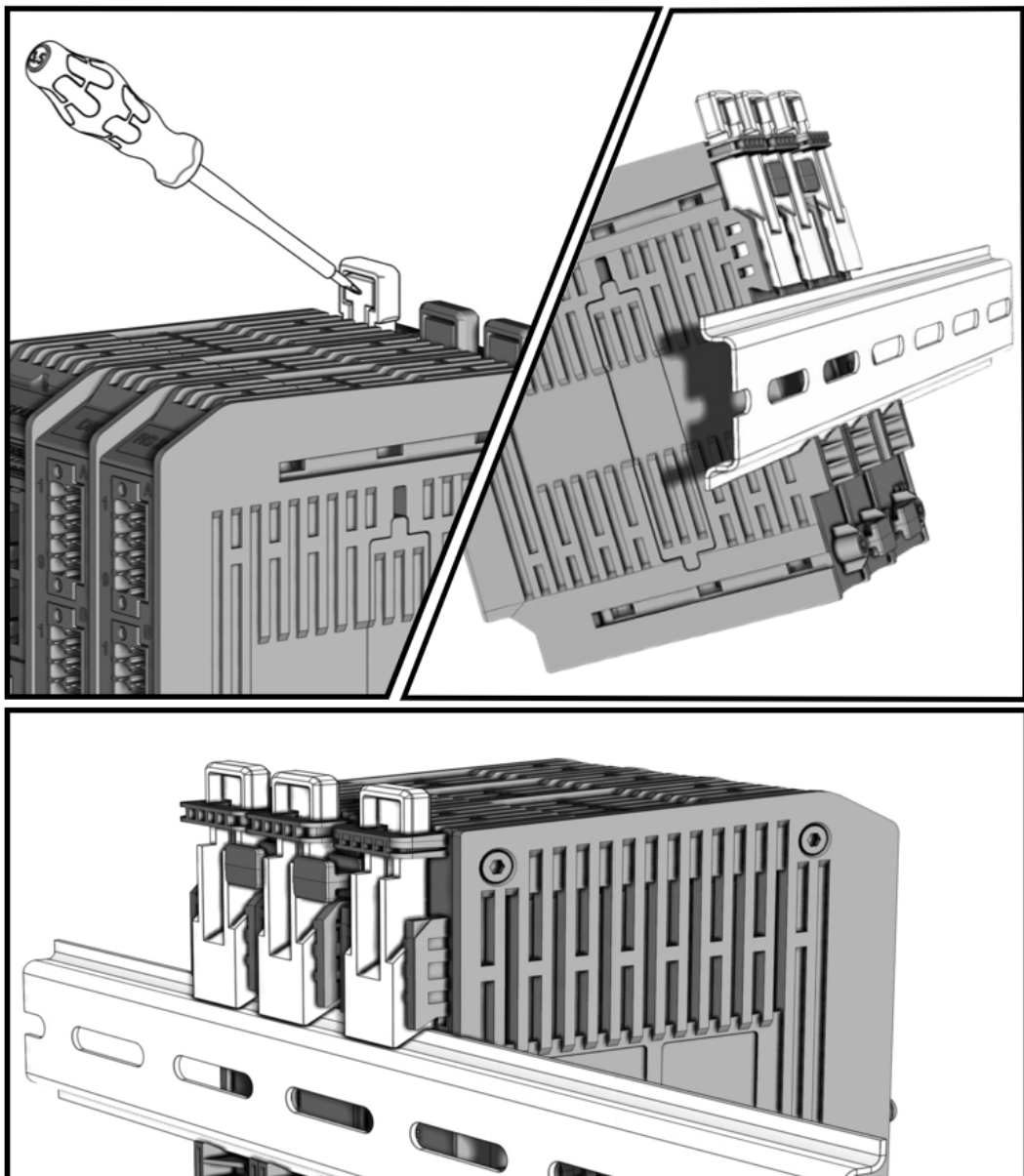

### 5.3.1 Attaching Gateway to DIN Rail

- Verify that the Gateway and all connected I/O Expansion Modules have DIN latches installed.
- Verify that all modules are secured together with top and bottom secure clamps.
- Raise up all the DIN latches. A screwdriver tip can be used to push on the “lever” and pull the latch up.
- Place the Gateway assembly on the DIN rail. Connect the bottom “teeth” first.
- Verify that the Gateway assembly is aligned on both sides of the DIN rail and push the latches down. There is a click once the latch is secured in position.
- Verify that all modules have latches closed.

### 5.3.2 Detaching Gateway from DIN Rail

- Raise up all latches. A screwdriver tip can be used to push on the “lever” and pull the latch up.
- Remove the Gateway assembly from the DIN rail. Disconnect the top “teeth” first.

## 6 OPERATING THE GATEWAY

---

### 6.1 Connecting with the gateway

- Prepare host PC with Linux or Windows OS
- Connect the gateway Console port (Figure 1/7) with the host PS using standard USB cable
- Verify the host PC has detected a new serial port (COM or ttyUSB)
- Start new terminal session using terminal emulation such as PuTTY or Minicom with the following port settings:

Baud Rate	Data Bits	Stop Bits	Parity	Flow Control
115200	8	1	none	none

### 6.2 Powering on the gateway

- IOT-DIN-IMX8PLUS should be powered from 12V or 24V DC source
- Ensure that the power input connector (Figure 1 /11) is fastened with the screws and V+, V0 wires are connected.
- Apply DC voltage to the device. The Gateway will power on automatically once the voltage is applied. System status LED will light blue.

### 6.3 Gateway Software

- IOT-DIN-IMX8PLUS units ordered with “XL” configuration option are pre-loaded with Compulab Debian Linux. Upon power-on the gateway will boot into the operating system.
- Gateways ordered without “XL” configuration option are pre-loaded only with the U-boot bootloader.
- For IOT-DIN-IMX8PLUS software documentation please refer to <https://www.compulab.com/products/iot-gateways/iot-din-imx8plus-industrial-iot-gateway/#devres>

## 7 DECLARATION OF CONFORMITY



**IOT-DIN-IMX8PLUS**

Manufacturer: Compulab Ltd.

This device complies with Part 15 of the FCC Rules.

Operation is subject to the following two conditions:

- (1) This device may not cause harmful interference, and
- (2) This device must accept any interference received, including interference that may cause undesired operation.

**Statement**

Changes or modifications to this equipment not expressly approved by the party responsible for compliance (Compulab Ltd.) could void the user’s authority to operate the equipment.

Statement

NOTE: This equipment has been tested and found to comply with the limits for a Class B digital device, pursuant to part 15 of the FCC Rules. These limits are designed to provide reasonable protection against harmful interference in a residential installation. This equipment generates, uses and can radiate radio frequency energy and, if not installed and used in accordance with the instructions, may cause harmful interference to radio communications. However, there is no guarantee that interference will not occur in a particular installation. If this equipment does cause harmful interference to radio or television reception, which can be determined by turning the equipment off and on, the user is encouraged to try to correct the interference by one or more of the following measures:

- Reorient or relocate the receiving antenna.
- Increase the separation between the equipment and receiver.
- Connect the equipment into an outlet on a circuit different from that to which the receiver is connected.
- Consult the dealer or an experienced radio/TV technician for help.

**WEEE**



This symbol means that you must dispose of an electrical item AND/OR containing in it Li-Mn battery separately from general household waste when they reach the end of their useful life. Take your PC or the battery to your local waste collection point or center. This applies to all countries of the European Union, and to other countries with a separate waste collection system.